

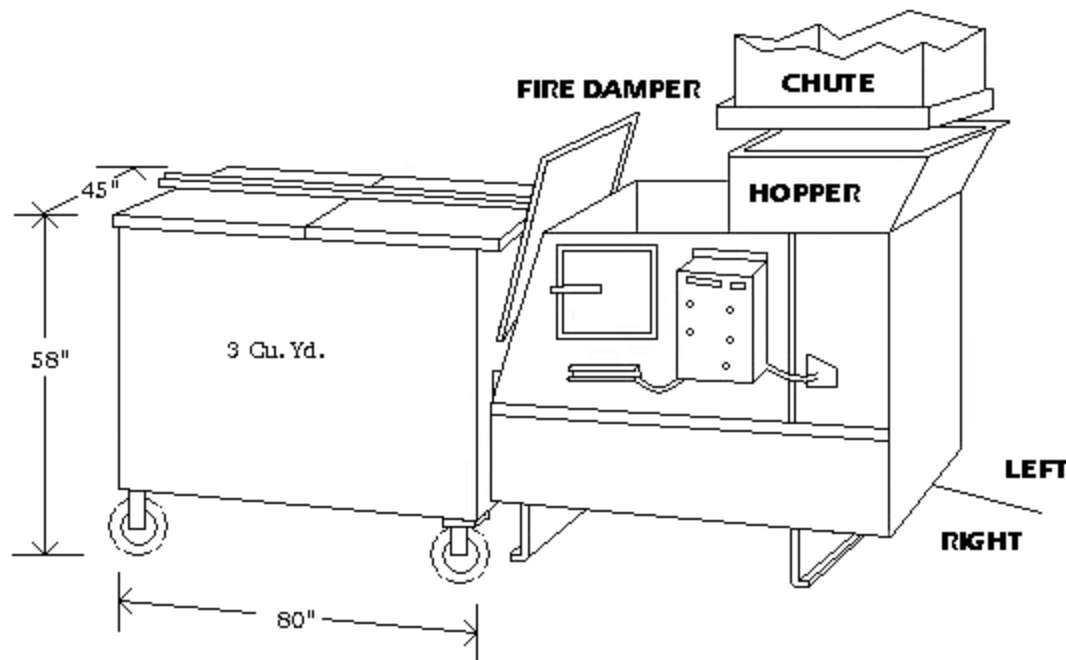

HYDRA-PAK Model 180

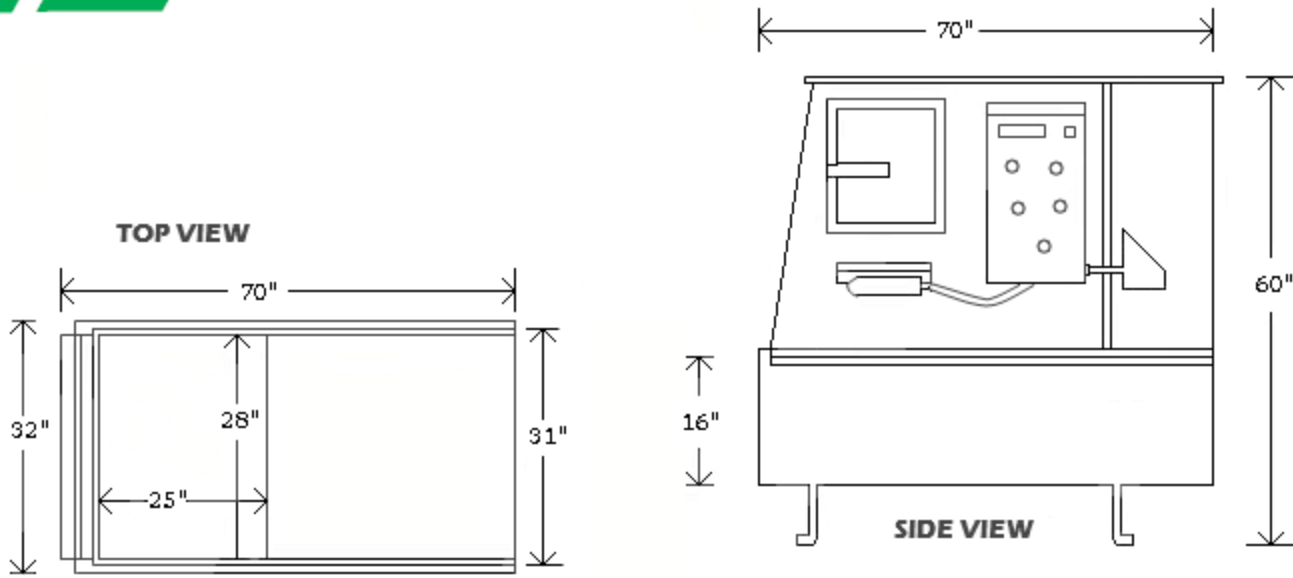

Clear Top Opening: 28" x 25"	Factory Rating: .25 Cu. Yd.	Motor: 3 HP	Pump: 3 GPM
No. of Cylinders: 1	Cylinder Bore: 3.5"	Ram Stroke: 30"	Max. Pressure: 1200 PSI
Ram Face: 336 Sq. In.	Ram Face Pressure: 30 PSI	Cylinder Force: 10,000 lbs	Cycle Time: 30 seconds
Base Unit Weight: 1,600 lbs			

**Specifications are approximate and subject to change without notification.
Dimensions will vary with options in Compactor and Container size.**

TOPLINE RECYCLING EQUIPMENT LTD.

**6175 Kestrel Road
Mississauga, Ontario L5T 1Z2
905-829-5030 / 1-800-391-5030
email: info@toplinerecycling.com**