

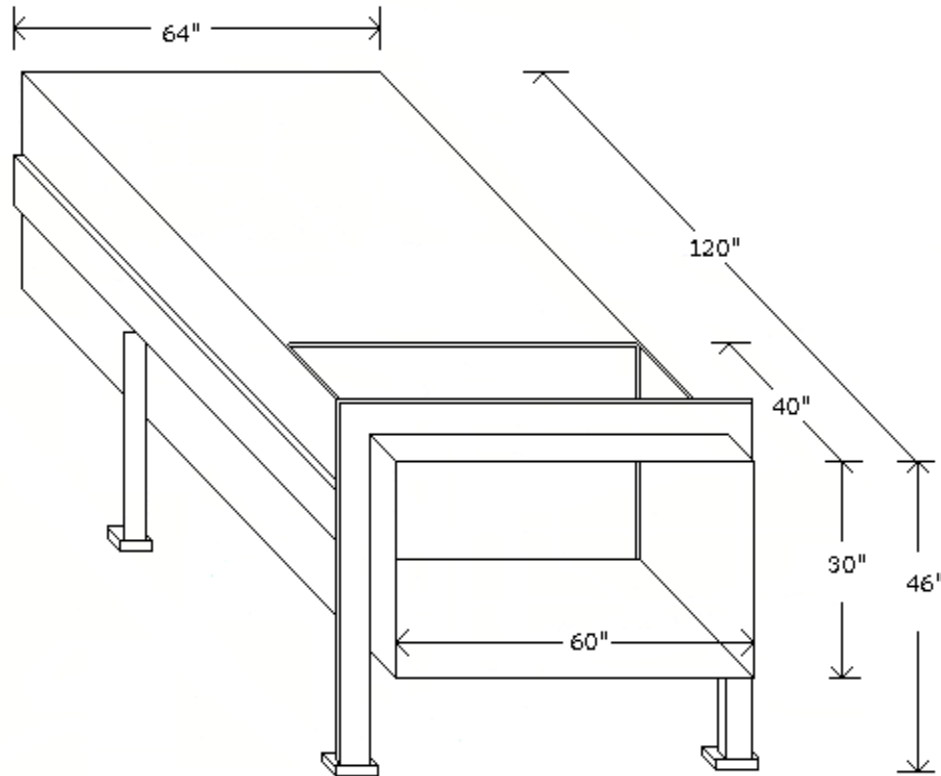

# HYDRA-PAK Model 1500E



## SPECIFICATIONS

### MECHANICAL

Compactor Weight:	Gross 5768 lbs.
Charging Chamber Cap:	1.5 Cu. Yds.
Chamber Opening:	40" x 60" x 36"
Ram Face Diameter:	60" x 24"
Ram Penetration:	10 inches

### CONSTRUCTION

Sides 1/4", floor 3/8"  
Hot Rolled Steel  
Reinforced 3" x 6" x 1/4"

### ELECTRICAL

Control System:	110 volts, 60 cycles
Motor:	10HP 3 Phase 60 Cycles, Power Range - 208-416-230-460-575 volts
Control Panel:	Fully wired with fuse protection, on-off switch, start-stop button, on indicator light, full indicator light.

### HYDRAULICS

Compaction Force:	51,000 lbs. maximum
Compaction Force:	46,600 lbs. normal
Max. Displacement:	90 Cu. Yd. per Hour
Cycle Time:	65 seconds
Pressure:	
Normal:	1,650 psi
Maximum:	1,800 psi
Pump Capacity:	10 G.P.M.
Cylinder:	One 6" bore, 52" stroke
Ram Pressure:	32 psi
Oil Capacity:	30 gallons

**Specifications are approximate and subject to change without notification.  
Dimensions will vary with options in Compactor and Container size.**

---

**TOPLINE RECYCLING EQUIPMENT LTD.**

**6175 Kestrel Road**

**Mississauga, Ontario L5T 1Z2**

**905-829-5030 / 1-800-391-5030**

**email: [info@toplinerecycling.com](mailto:info@toplinerecycling.com)**